

ohne Ausrundung
km 0+126.441
h TS = 443.300 m

ohne Ausrundung
km 0+119.941
h TS = 443.137 m





H = 1000.000 m
T = 16.730 m
f = 0.140 m
km = 0+035.453
h TS = 439.409 m

H = 1000.000 m
T = 11.991 m
f = 0.072 m
km = 0+103.057
h TS = 442.716 m

ohne Ausrundung
km 0+000.000
h TS = 438.861 m

ohne Ausrundung
km 0+139.941
h TS = 443.300 m

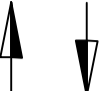

Zeichenerklärung

 Gradientenhochpunkt
 Gradiententiefpunkt
 Ausrundungsbeginn Kuppe / Ausrundungsende Wanne
 Tangentenschnittpunkt

H = 15.000 m
 T = 362.155 m
 f = 4.372 m
 km = 0+601.335
 hTS = 415.868 m

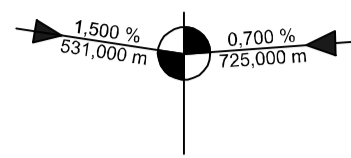
Neigungsbrechpunkt mit Angabe von:
 Ausrundungshalbmesser, Tangentenlänge, Stichhöhe, Bau-km, Höhe Tangentenschnittpunkt

 Längsneigung und Abstand zum nächsten Neigungsbrechpunkt

 Dammbauwerk
 Einschnittbauwerk

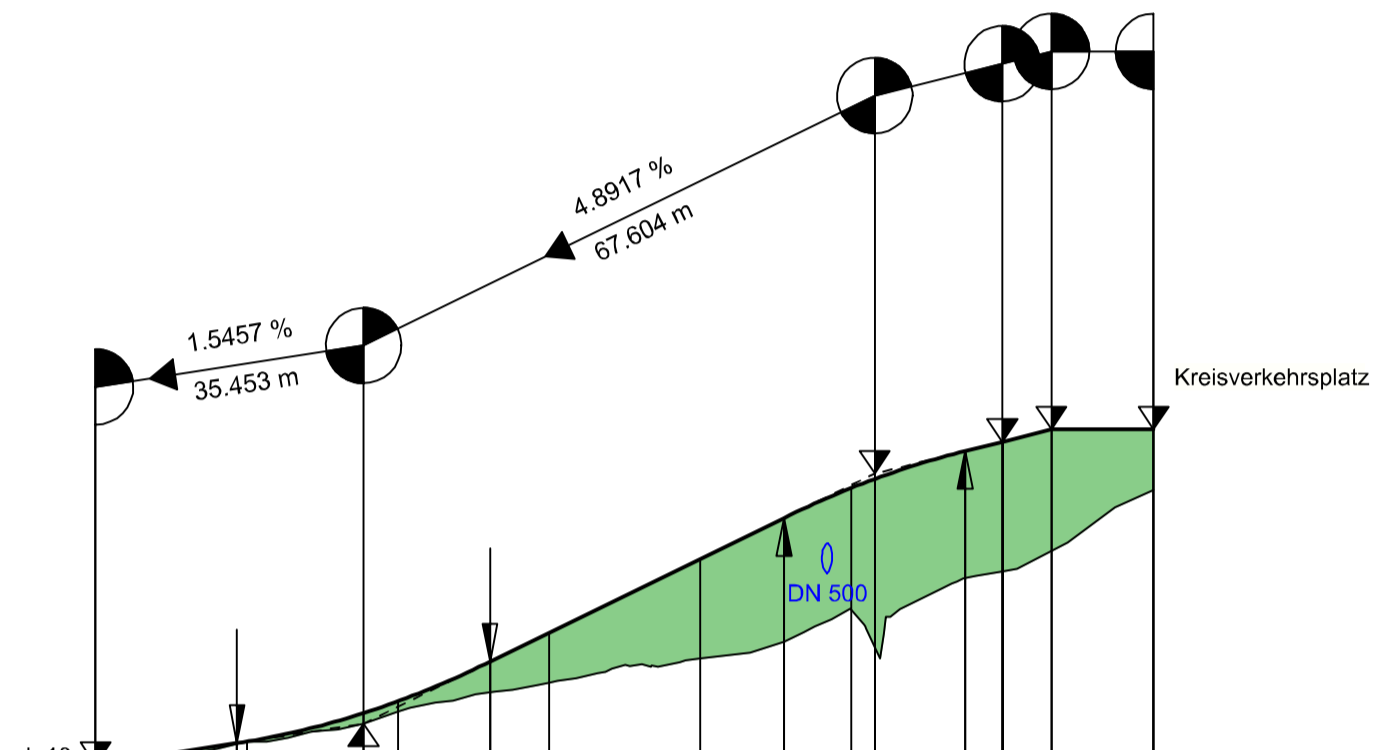

↙ NN 435.000 m

Höhe Gradiente L/A

Geländehöhe

Station Querprofil

0.000	20.000	40.000	60.000	80.000	100.000	120.000	139.941
000.000	030.706	039.818	053.165	074.843	082.843	104.013	139.941

Krümmung
200 / R (cm)

Rechtskurve
Linkskurve

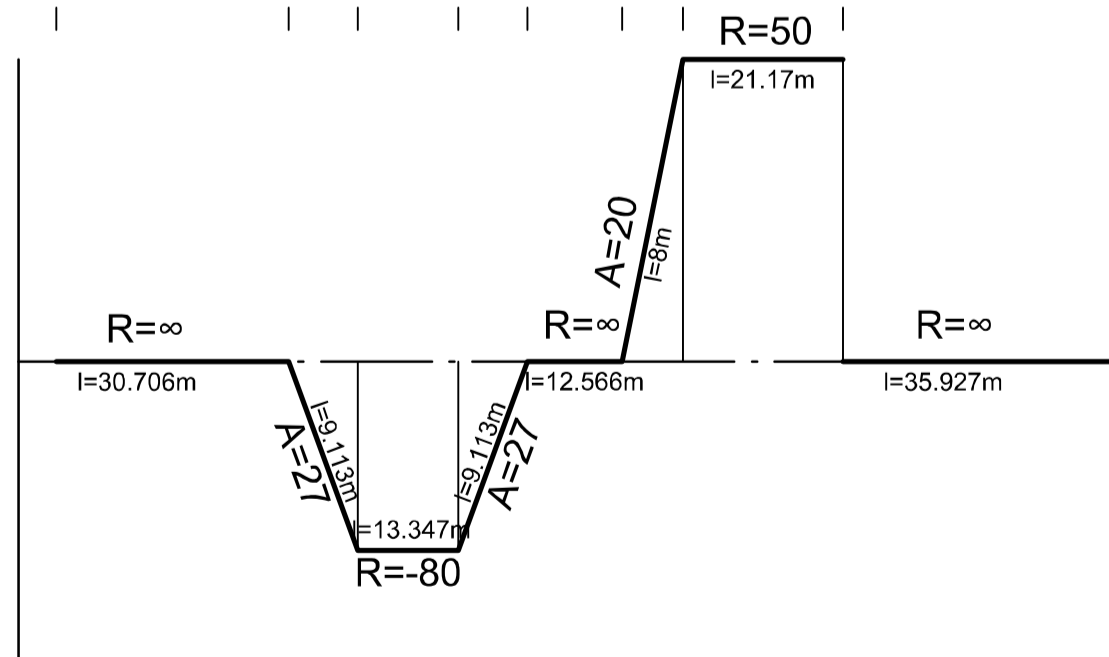

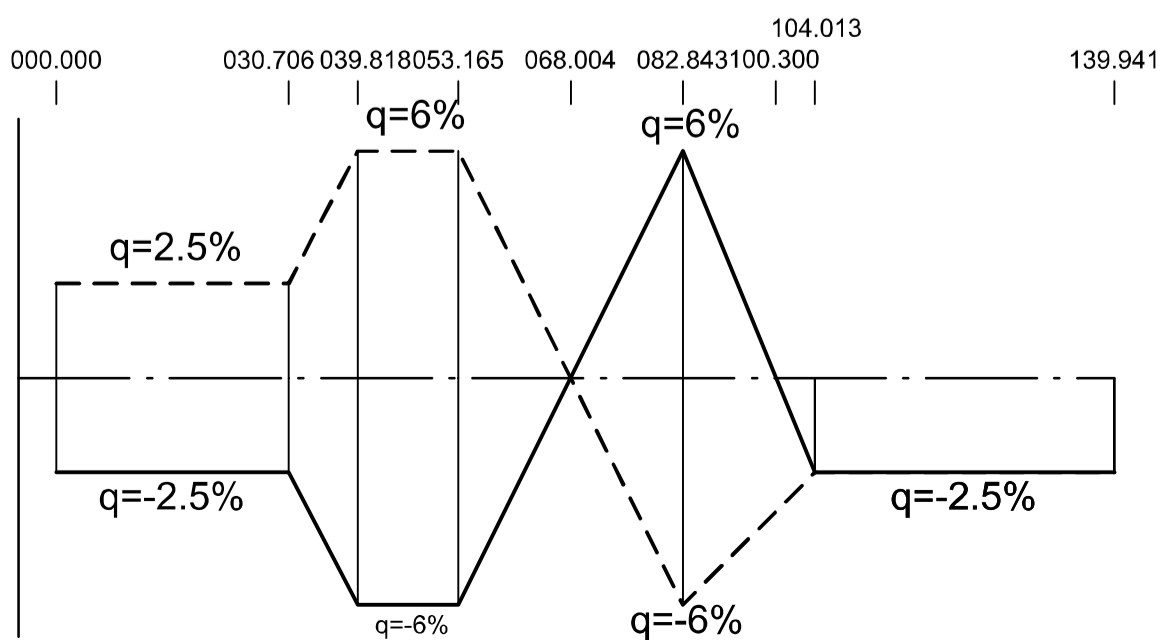

Querneigung

bezogen auf 2.00 % / cm
linker Fahrbahnrand
rechter Fahrbahnrand

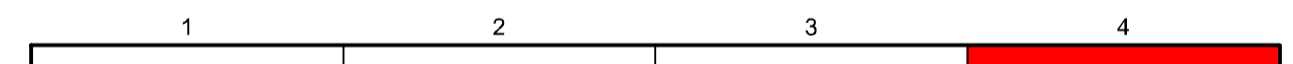

c			
b			
a			
Nr.	Art der Änderung	Datum	Name



 Landesbetrieb Mobilität Trier Dasbachstraße 15c 54292 Trier Tel.: 0651/9796-0 Fax: 0651/9796-1480		Datum	Name
	bearbeitet:	03/2018	He / Ko
	gezeichnet:	03/2018	He / Ko
	geprüft:	29/03/2018	gez. Bauch

FESTSTELLUNGSENTWURF

Straßenbauverwaltung:  Rheinland-Pfalz	Unterlage: 6 Blatt-Nr.: 1d Höhenplan Achse 116 Provisor. Anbindung A 1 / L 167 / L 10 als Kreisverkehrsplatz (KVP)	
PROJIS-Nr.: 0768725720	SAP-Nr.: A.71-02-0019.02	Maßstab: 1 : 1.000/100

**Neubau der A 1
AS Kelberg (B 410) - AS Adenau (L 10)**
Bau-km 4+920 bis Bau-km 15+466,325

aufgestellt:	
Trier, den 03.04.2018	